



PAGID

BRAKE SYSTEMS

**ELECTROMECHANICAL
PARKING BRAKE**



PURPOSE OF THE PARKING BRAKE

A parking brake secures a stopping or parked vehicle against rolling off, also on inclined roads and in the absence of a driver.

Due to safety reasons, the components must act mechanically and are generally activated by foot pedal- and/or hand lever-operated linkages or cable pulls.

The parking brake acts on the axle wheels and must be lockable or fixable. The parking brake should simultaneously serve as an auxiliary braking system in case of service brake failures. In modern vehicles, electromechanical control via a control button or actuators is increasingly common.

This "electronic handbrake" is increasingly common in modern passenger cars, replacing the conventional manual parking brake. Depending on vehicle manufacturer, different systems are available on the market.

Below, we therefore would like to take a closer look at the electromechanical parking brake (EMF), often also called electrical parking brake (EPB).

We consider the electromechanical parking brake of the Audi A4 to be a good example of this.

System setup

Brake caliper with brake actuator (Fig. 1)

The electromechanical setting unit (brake actuator) is mounted to the hydraulic part of the rear axle's brake caliper.

Control unit of the electromechanical parking brake (Fig. 2)

The control unit is situated in the trunk on the right side below the tool kit. All control, steering and diagnosis tasks occur here in a process-controlled manner. The data exchange with the ABS control unit occurs via the CAN data bus.

Clutch position sensor

This sensor is situated by the clutch master cylinder. The sensor signal is required for the "Dynamic start-up assistant" function.

Activation button (Fig. 3)

This button (1) activates / deactivates the electromechanical parking brake. This control button simultaneously houses the indicator lamp for the parking brake.

Button for start-up assistant

This button (2) switches the start-up assistant on/off. The control button is situated in the centre console to the left of the gear lever.

Indicator lamp for parking brake (Fig. 4)

The indicator lamp integrated in the instrument cluster glows when parking brake is activated.

Warning lamp (Fig. 5)

Any error is indicated by a warning lamp in the control switchboard panel.



Figure 1



Figure 2



Figure 3

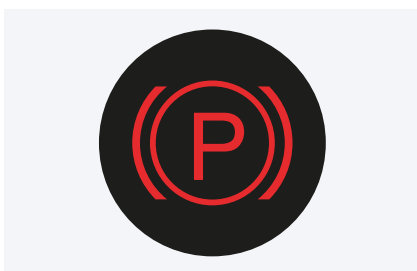

Figure 4



Figure 5

Multi-lane vehicles must be equipped with two brake systems operating independently of each other.

The operating device of the second brake system must be lockable (Excerpt STVZO §41/5, EC 98/12)

Rear wheel brake caliper with brake actuator

The known mechanical handbrake lever function of the brake caliper of a traditional handbrake is replaced by an electrical assembly group, the brake actuator.

The brake actuator consists of a DC engine, a wobble plate gear and a spindle. The DC engine powers the wobble plate gear via a belt drive throughout. A spindle directly powered by the wobble plate gear achieves the conversion of a torque into a lifting motion. The brake piston houses a cylinder that can move back and forth inside the piston. In order to prevent the cylinder in the piston from turning, it is surface-ground on two locations.

A pressure nut is pressed onto the cylinder front end, which moves on the spindle thread as soon as the spindle rotates. Internal conversion ratios inside the transmission reduce spindle speed. The speed at the spindle drive has been reduced by a factor of 150 towards the drive speed of the DC engine.

Once the parking brake is activated, the rotation of the spindle moves the pressure nut forward. The cylinder then presses the brake pads to the brake disc via the brake piston. Once the parking brake is released, the pressure nut on the spindle is reversed and the brake piston is discharged. Thanks to the reversal in shape of the piston sealing ring, the brake piston reverts to default as is the case after regular braking.

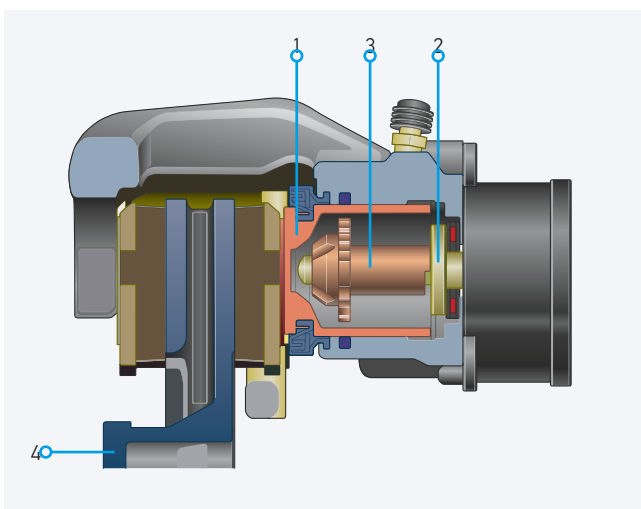

1. Brake piston, 2. Spindle, 3. Cylinder, 4. Brake disc

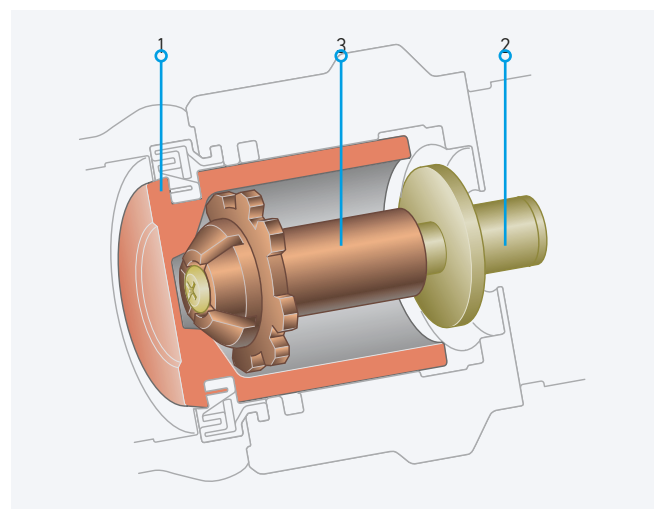

ADVANTAGES AND FUNCTIONS OF THE ELECTROMECHANICAL PARKING BRAKE

Compared to the traditional handbrake, the electromechanical parking brake has many advantages. Thanks to the omission of the handbrake lever, more interior design options result as well as simpler assembly and production processes. The electronic control and system connections allow for additional comfort functions and system diagnosis.

Compared to the traditional handbrake, the electromechanical parking brake additionally provides the following comfort and safety features:

- Parking brake function
- Emergency brake function
- Start-up assistant

Parking brake

The parking brake can be activated with the ignition turned on or off.

Deactivation is only possible with ignition switched on. If the driver door is closed, the belt buckled and the engine turned on, the parking brake is released automatically upon acceleration.

Once the vehicle is deposited and the parking brake activated, the system automatically activates the required clamping force in order to avoid unwanted rolling off.

When parking the vehicle at an inclination of more than 30%, the instrument panel emits a warning. As the brake discs cool down during idling, the control unit automatically adjusts the brakes. This occurs via a simulation model in the control unit, which determines the current brake disc temperature.

Emergency brake

If the service brake has failed, it is possible to activate an emergency brake function by pulling and holding down the control button. The stop lamps are activated and an acoustic warning signal occurs. Throughout, the function of the normal control button matches that of a normal handbrake lever. If the vehicle speed exceeds 7km/h, the intervention occurs via a hydraulic pressure buildup on all four wheels, which is controlled via the ABS control unit. At speeds below 7km/h, the electromechanical parking brake is activated. Simultaneously, the engine moment is reset in case of activated gas pedal while the possibly activated cruise control system is turned off. As long as the control button is activated, the vehicle will slow down. Once the control button is released, the braking process is disrupted. The maximum delay is approx. 6 m/s. The braking effect is comparable to an emergency braking. In order to avoid an operating error (triggering by passenger) the emergency brake is deactivated if the driver further accelerates

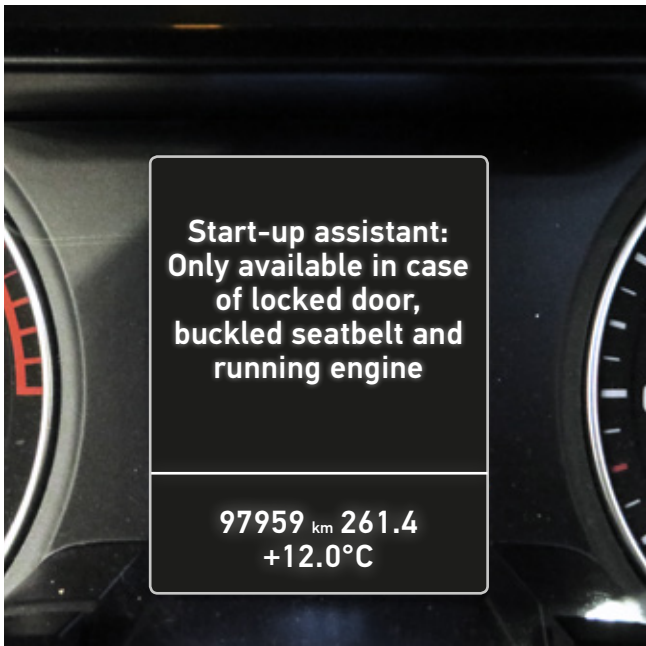

Start-up assistant

The start-up assistant supports the driver during the acceleration processes, going forward and backward and when the vehicle is at a standstill. This function only gets activated when:

- The driver's door is closed
- The safety belts are buckled
- The engine has started

Activating and deactivating via control button in centre control to the left of the gear lever. Activation is displayed by the flashing indicator lamp on the control button.

In order to optimally use the start-up assistant, the control unit requires additional information from the board network. To this end, information from the CAN bus are taken into account, like the selected driving level, clutch operation, gas pedal position, wheel speed, engine torque as well as the inclination angle sensor integrated into the control unit.

The following assistance functions are supported:

- Start-up assistant
The start-up assistant supports the driver during acceleration on a mountain and prevents unwanted reversing.
- Automatic parking
If the vehicle is parked with activated function while the ignition is turned off, and the door opens, the parking brake activates automatically.
- Stop-and-go assistant
Automatic braking for idle vehicle during stop-and-go traffic.

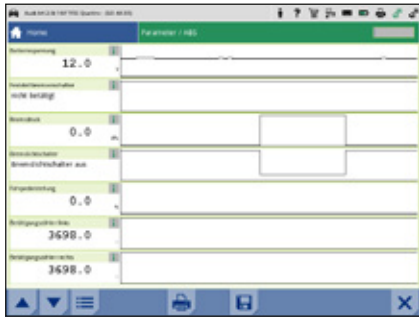

Figure 1

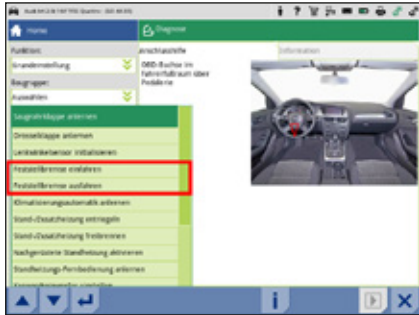

Figure 2



Figure 3



DIAGNOSIS AND MAINTENANCE

The system functions of the electromechanical parking brake are constantly monitored. Occurring errors are deposited in the control unit's error storage and can be selected using a suitable diagnostic unit. Depending on the system, it is additionally possible to display various parameters (Fig. 1) and use them for error search. In case of maintenance and repair to the rear wheel brake unit, e.g. for changing the brake pads, a diagnosis and brake service device will also be required.

Before the brake pistons can be pushed back, the pressure nuts must first be repositioned on the spindle drives.

Example of repair process for exchanging brake pads:

- Connect the diagnostic unit.
- Selection function "Basic settings/ Set parking brake" (Fig. 2).
- Upon terminating the process, switch off ignition and remove ignition key from the vehicle.
- For exchanging brake pads, push back the brake piston using a suitable reset tool (Fig. 3).
- Following repair, connect the diagnostic unit, activate the ignition.
- Select function "Basic setting/ Release parking brake".
Pressure nuts are released from spindle operations.
- Operate brake pedal with 2/3 of the activation distance multiple times.
This will result in the brake pistons being positioned in the operating position by the brake pads.

Inspection on brake test stand

A meaningful functional test of the electromechanical parking brake is only possible on the chassis dynamometer. A test mode of the control unit allows conducting an adjustable braking process. The test mode is automatically detected when the front wheels are idle and the rear wheels are rotating at a speed of 2.5 to 9 km/h.

Test procedure:

1. Drive vehicle rear wheels onto test stand.
Front wheel must have firm stand.
2. When the rear wheels are turning and the test mode has been recognised, a yellow-striped symbol of the parking brake will light up in instrument panel.
Activate control button in short intervals 3x.
Each activation extends the brake piston by a defined distance.
After 3x activation, the parking brake is completely closed.

The parking brake can be released via renewed pressing of button.

Note:

A brake pad change without diagnosis or brake service device is not properly possible in this brake system.

In this context, please always observe the assembly and repair instructions of the brake and vehicle manufacturers.



EMERGENCY RELEASE

The vehicles dispose of an emergency release enabling the driver or the workshop to unlock the parking brake in case of system failure.

Normally, the tool kit contains a special torx key.

Emergency release parking brake:

- Turn off the ignition
- Remove the ignition key from the vehicle
- Dismount wheels of rear axle
- Disconnect the electric plug connection of the actuator
- Undo and remove the fixing screws of the actuator
- Uninstall the actuator and sealing rings
- Mechanically reset brake pistons by turning spindles

Installation occurs in reverse order.

Conduct basic setting using a diagnosis unit thereafter.



Cable puller unit Opel Astra J

System versions

A further system version of the electronic handbrake is the cable puller system. This system replaces the handbrake lever with an electronically controlled motor gear unit, allowing the flawless integration in already existing systems. This actuator controls the cable pulls and thus creates the desired clamping force for the brake calipers or the brake drums of the rear axles.

This system assumes the pulling of the brake when parking, the comfort functions as well as accelerating on a mountain or the automatic adjustment of the cable pulls.

Depending on the car manufacturer, these systems can be designed differently and should be inspected and repaired according to manufacturer instructions in the context of servicing or repair works.

Copyright

This document must be treated confidentially. Its contents may be passed on, duplicated, exploited or disclosed only with our express permission. All rights reserved, especially the right to apply for protective rights.

HELLA KGaA Hueck & Co.

Rixbecker Straße 75
59552 Lippstadt, Germany
Tel.: +49 2941 38-0
Fax: +49 2941 38-7133
Internet: www.hella.com

HELLA PAGID GmbH

Lüschershofstraße 80
45356 Essen, Germany
www.hella-pagid.com
© HELLA PAGID GmbH
922 999 139-602 J01331/KB/04.17/0.15
Subject to technical and price modifications
Printed in Germany